

Electric Powered Forklift

7FB

1.5 to 3.5 ton

Series

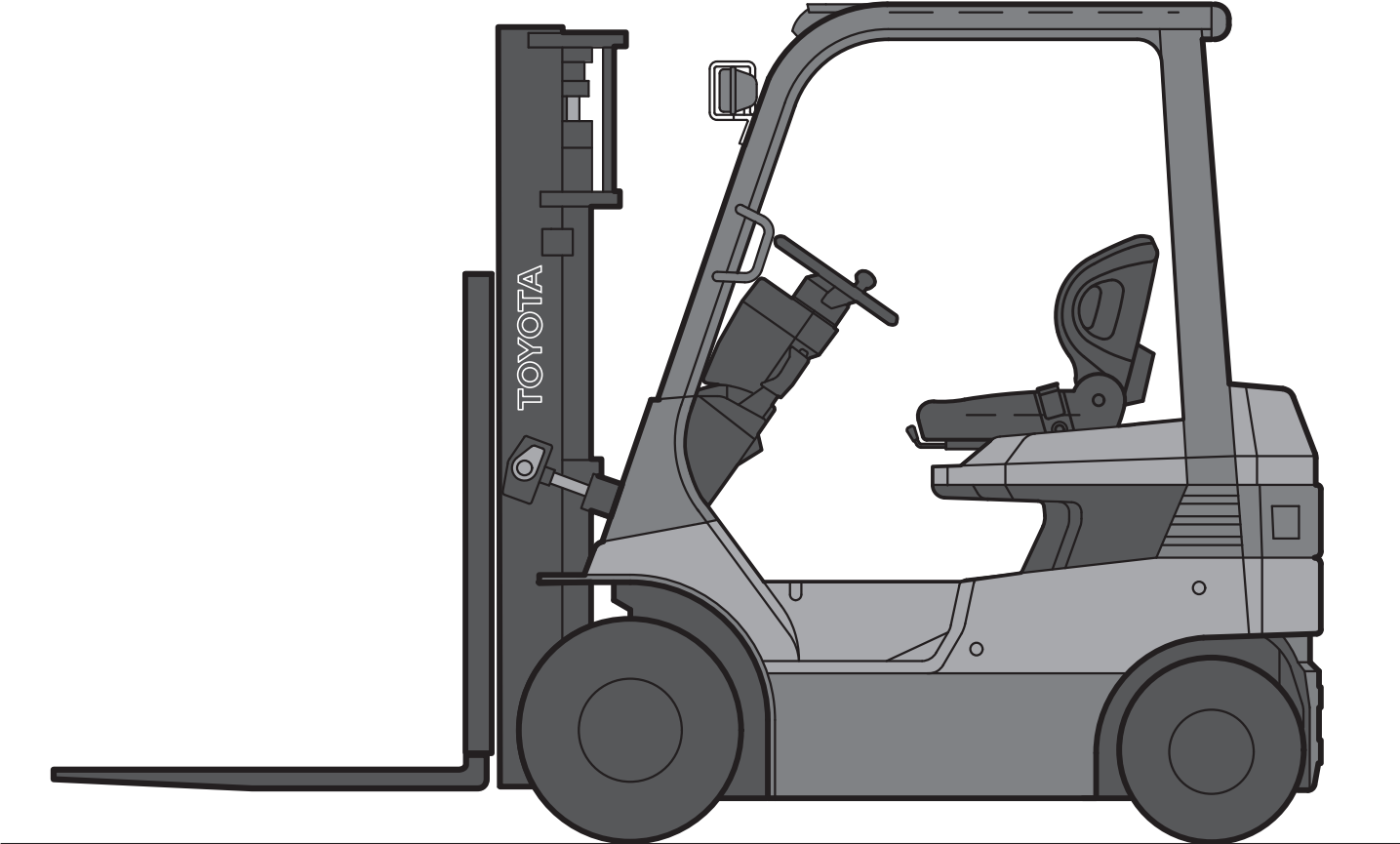

1,500 - 1,750 kg

MAIN VEHICLE SPECIFICATIONS

Characteristics	1.1	Manufacturer			TOYOTA	TOYOTA	TOYOTA	TOYOTA
	1.2	Model			7FB15	7FBH15	7FB18	7FBH18
	1.3	Power			electric	electric	electric	electric
	1.4	Operator Type			rider seated	rider seated	rider seated	rider seated
	1.5	Load capacity/rated load	Q	kg	1500	1500	1750	1750
	1.6	Load centre	c	mm	500	500	500	500
	1.8	Load distance, centre of drive axle to fork	x	mm	405	405	405	405
	1.9	Wheelbase	y	mm	1410	1410	1410	1410
	Weight	2.1	Truck weight ¹⁾		kg	2890	3060	3070
2.2		Axle loadings, laden front/rear		kg	3890/500	3970/590	4290/530	4370/620
2.3		Axle loadings, unladen front/rear		kg	1430/1460	1510/1550	1420/1650	1500/1740
Tyres, chassis	3.1	Tyres - pneumatic (P), pneumatic shaped cushion (SE), solid rubber (R)			P	P	P	P
	3.2	Tyre size - front			6.00-9-10PR (I)	6.00-9-10PR (I)	21x8-9-10PR (I)	21x8-9-10PR (I)
	3.3	Tyre size - rear			5.00-8-8PR (I)	5.00-8-8PR (I)	5.00-8-10PR (I)	5.00-8-10PR (I)
	3.5	Wheels - number front/rear (x = driven wheels)			2x/2	2x/2	2x/2	2x/2
	3.6	Tread - front	b ₁₀	mm	960	960	920	920
	3.7	Tread - rear	b ₁₁	mm	895	895	895	895
	Dimensions	4.1	Tilt of mast/fork carriage forward/backward	α/β	deg	7/11	7/11	7/11
4.2		Height, mast lowered	h ₁	mm	1970	1970	1970	1970
4.3		Free lift	h ₂	mm	145	145	145	145
4.4		Lift	h ₃	mm	3000	3000	3000	3000
4.5		Height, mast extended	h ₄	mm	4220	4220	4220	4220
4.7		Height of overhead guard	h ₆	mm	2025	2105	2025	2105
4.8		Seat height	h ₇	mm	985	1065	985	1065
4.12		Coupling height	h ₁₀	mm	430	430	430	430
4.19		Overall length	l ₁	mm	3150	3150	3185	3185
4.20		Length to face of forks	l ₂	mm	2080	2080	2115	2115
4.21		Overall width	b ₁	mm	1115	1115	1115	1115
4.22		Fork dimensions	s/e/l	mm	35/100/1070	35/100/1070	35/100/1070	35/100/1070
4.23		Fork carriage DIN 15 173, class/type A, B			II	II	II	II
4.24		Fork carriage width	b ₃	mm	920	920	920	920
4.31		Ground clearance, laden, below mast	m ₁	mm	85	85	85	85
4.32		Ground clearance, centre of wheelbase	m ₂	mm	85	85	85	85
4.33		Aisle width for pallets 1000x1200 wide*	A _{st}	mm	3376	3376	3386	3386
4.34		Aisle width for pallets 800x1200 long*	A _{st}	mm	3576	3576	3586	3586
4.35	Turning radius	W _a	mm	1770	1770	1780	1780	
4.36	Internal turning radius	b ₁₃	mm	557.5	557.5	557.5	557.5	
Performance	5.1	Travel speed, laden/unladen		km/h	14.5/17	14.5/17	14.5/17	14.5/17
	5.2	Lift speed, laden/unladen		m/s	0.42/0.65	0.42/0.65	0.37/0.65	0.37/0.65
	5.3	Lowering speed, laden/unladen		m/s	0.50/0.55	0.50/0.55	0.50/0.55	0.50/0.55
	5.5	Drawbar pull, laden/unladen ²⁾		N	2750/2750	2750/2750	2750/2940	2750/2940
	5.6	Max. drawbar pull, laden/unladen ²⁾		N	7850/7550	7850/7550	8040/7550	8040/7550
	5.7	Gradeability, laden/unladen ²⁾		%	12/19	12/19	11/18	11/18
	5.8	Max. gradeability, laden/unladen ²⁾		%	19/25	19/25	17/23	17/23
	5.9	Acceleration time, laden/unladen		s	4.6/4.1	4.6/4.1		
	5.10	Service brake			hydraulic	hydraulic	hydraulic	hydraulic
	Motor	6.1	Drive motor rating S2 60min		kW	7.6	7.6	7.6
6.2		Lift motor rating S3 15%		kW	9.5	9.5	9.5	9.5
6.3		Battery acc. to DIN 43 531 35/36 A, B, C			-	-	-	-
6.4		Battery voltage/nominal capacity		V/Ah	48/400	48/545	48/400	48/545
6.5		Battery weight ³⁾		kg	670	820	670	820
6.6		Energy consumption acc to VDI cycle		kWh/h				
Others	8.1	Type of drive control			transistor inverter	transistor inverter	transistor inverter	transistor inverter
	8.2	Operating pressure for attachments		bar	118	118	118	118
	8.3	Oil volume for attachments		l/min	45	45	45	45
	8.4	Sound level at the driver's ear according to EN 12 053		dB(A)	68	68	68	68
	8.5	Towing coupling, type DIN						

* aisle width calculation based on VDI 2198

¹⁾ With h₃ = 3000 mm and battery weight = 670/820 kg (7FB15.18/ 7FBH15.18)

²⁾ Computed values

³⁾ Min. battery weight required by Toyota = 655/805 kg (7FB15.18/ 7FBH15.15)

7FB(H)15, 7FB(H)18

DIMENSIONAL DRAWINGS

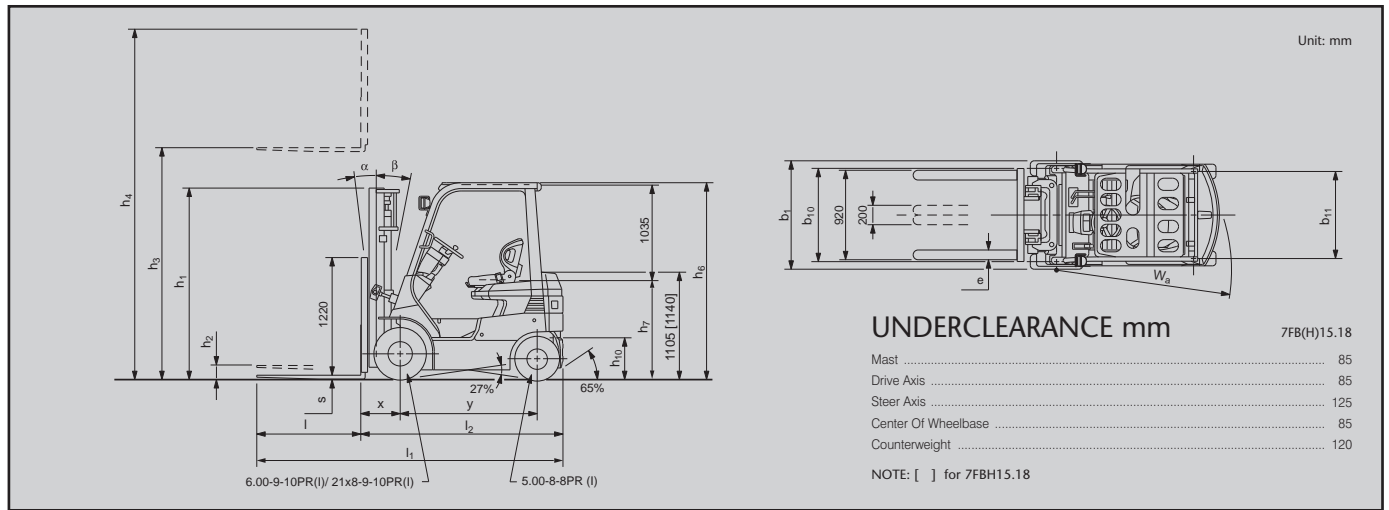

SPECIAL TREAD

Model	7FB(H)15					7FB(H)18			
	Single	Single	Single	Dual	Dual	Single	Single	Dual	Dual
Front Tyre Single/Dual	6.00-9-10PR (I)	21x8-9-10PR(I)	6.50-10-12PR (I)	4.50-12-8PR (I)	6.00-9-10PR (I)	21x8-9-10PR (I)	6.50-10-12PR(I)	4.50-12-8PR (I)	6.00-9-10PR (I)
Overall Width	mm 1115	1115	1115	1295	1435	1115	1115	1295	1435
Tread, Front	mm 960	920	940	1010	1085	920	940	1010	1085

MAST SPECIFICATION & RATED CAPACITIES

Model	Mast Type	Maximum Fork Height h_3	Overall Height		Free Lift		Single Tyre		Dual Tyre			
			*Lowered h_1	Extended Without Load Backrest h_4	Without Load Backrest h_2	With Standard Load Backrest h_2	Tilt Range		Tilt Range		Load Capacity at 500 mm LC kg	
			mm	mm	mm	mm	FWD deg	BWD deg	FWD deg	BWD deg		
7FB(H)15	V	3000	1970	3605	145	145	7	11	1500	7	11	1500
		3300	2120	3905	145	145	7	11	1500	7	11	1500
		3500	2220	4105	145	145	7	11	1500	7	11	1500
		3700	2380	4305	145	145	7	11	1500	7	11	1500
		4000	2570	4605	145	145	7	11	1500	7	11	1500
		4500	2820	5105	145	145	7	5	1450	7	5	1450
	SV	3000	1970	3640	385	385	7	11	1500	7	11	1500
		3300	2120	3940	385	385	7	11	1500	7	11	1500
		3500	2220	4140	385	385	7	11	1500	7	11	1500
		3700	2380	4340	385	385	7	11	1500	7	11	1500
		4000	2570	4640	385	385	7	11	1500	7	11	1500
		4500	2820	5140	385	385	7	5	1450	7	5	1450
	FV	3000	1970	3565	1405*	750*	7	11	1500	7	11	1500
		3300	2120	3865	1555*	900*	7	11	1500	7	11	1500
		3500	2220	4065	1655*	1000*	7	11	1500	7	11	1500
		3700	2380	4265	1815*	1160*	7	11	1500	7	11	1500
		4000	2570	4565	2005*	1350*	7	11	1500	7	11	1500
		FSV	3700	1770	4240	1235*	550*	7	5	1400	7	5
	4000		1870	4540	1335*	650*	7	5	1400	7	5	1400
	4300		1970	4840	1435*	750*	7	5	1400	7	5	1400
	4500		2040	5040	1505*	820*	7	5	1350	7	5	1350
	4700		2120	5240	1585*	900*	7	5	1350	7	5	1350
	5000		2220	5540	1685*	1000*	7	5	1200	7	5	1300
	7FB(H)18	V	3000	1970	3605	145	145	7	11	1750	7	11
3300			2120	3905	145	145	7	11	1750	7	11	1750
3500			2220	4105	145	145	7	11	1750	7	11	1750
3700			2380	4305	145	145	7	11	1750	7	11	1750
4000			2570	4605	145	145	7	5	1750	7	11	1750
4500			2820	5105	145	145	7	5	1650	7	5	1650
SV		3000	1970	3640	385	385	7	11	1750	7	11	1750
		3300	2120	3940	385	385	7	11	1750	7	11	1750
		3500	2220	4140	385	385	7	11	1750	7	11	1750
		3700	2380	4340	385	385	7	11	1750	7	11	1750
		4000	2570	4640	385	385	7	5	1750	7	11	1750
		4500	2820	5140	385	385	7	5	1650	7	5	1650
FV		3000	1970	3565	1405*	750*	7	11	1750	7	11	1750
		3300	2120	3865	1555*	900*	7	11	1750	7	11	1750
		3500	2220	4065	1655*	1000*	7	11	1750	7	11	1750
		3700	2380	4265	1815*	1160*	7	11	1750	7	11	1750
		4000	2570	4565	2005*	1350*	7	11	1750	7	11	1750
		FSV	3700	1770	4240	1235*	550*	7	5	1600	7	5
4000			1870	4540	1335*	650*	7	5	1600	7	5	1600
4300			1970	4840	1435*	750*	7	5	1550	7	5	1550
4500			2040	5040	1505*	820*	7	5	1500	7	5	1500
4700			2120	5240	1585*	900*	7	5	1500	7	5	1500
5000			2220	5540	1685*	1000*	7	5	1250	7	5	1450

Note: Height of standard load backrest is 1220 mm; h_4 with standard load backrest is +615 mm (V), +580 mm (SV), +655 mm (FV), +680 mm (FSV)
* with optional tyre size; 6.50-10-12PR(I) plus 25mm.
Lower fork heights available

2,000 - 2,500 kg

MAIN VEHICLE SPECIFICATIONS

Characteristics	1.1	Manufacturer			TOYOTA	TOYOTA	TOYOTA	TOYOTA
	1.2	Model			7FB20	7FBH20	7FB25	7FBH25
	1.3	Power			electric	electric	electric	electric
	1.4	Operator Type			rider seated	rider seated	rider seated	rider seated
	1.5	Load capacity/rated load	Q	kg	2000	2000	2500	2500
	1.6	Load centre	c	mm	500	500	500	500
	1.8	Load distance, centre of drive axle to fork	x	mm	420	420	435	435
	1.9	Wheelbase	y	mm	1500	1500	1500	1500
	Weight	2.1	Truck weight ¹⁾		kg	3490	3805	3965
2.2		Axle loadings, laden front/rear		kg	4900/585	5030/775	5700/765	5800/845
2.3		Axle loadings, unladen front/rear		kg	1680/1805	1790/2015	1650/2315	1750/2395
Tyres, chassis	3.1	Tyres - pneumatic (P), pneumatic shaped cushion (SE), solid rubber (R)			P	P	P	P
	3.2	Tyre size - front			21x8-9-14PR (I)	21x8-9-14PR (I)	21x8-9-14PR (I)	21x8-9-14PR (I)
	3.3	Tyre size - rear			18x7-8-14PR (I)	18x7-8-14PR (I)	18x7-8-14PR (I)	18x7-8-14PR (I)
	3.5	Wheels - number front/rear (x = driven wheels)			2x/2	2x/2	2x/2	2x/2
	3.6	Tread - front	b ₁₀	mm	970	970	970	970
	3.7	Tread - rear	b ₁₁	mm	940	940	940	940
	Dimensions	4.1	Tilt of mast/fork carriage forward/backward	α/β	deg	7/11	7/11	7/11
4.2		Height, mast lowered	h ₁	mm	1975	1975	1975	1975
4.3		Free lift	h ₂	mm	125	125	130	130
4.4		Lift	h ₃	mm	3000	3000	3000	3000
4.5		Height, mast extended	h ₄	mm	4220	4220	4220	4220
4.7		Height of overhead guard	h ₆	mm	2025	2105	2025	2105
4.8		Seat height	h ₇	mm	985	1065	985	1065
4.12		Coupling height	h ₁₀	mm	425	425	280	280
4.19		Overall length	l ₁	mm	3310	3310	3360	3360
4.20		Length to face of forks	l ₂	mm	2240	2240	2290	2290
4.21		Overall width	b ₁	mm	1160	1160	1160	1160
4.22		Fork dimensions	s/e/l	mm	38/120/1070	38/120/1070	42/120/1070	42/120/1070
4.23		Fork carriage DIN 15 173, class/type A,B			II	II	II	II
4.24		Fork carriage width	b ₃	mm	1020	1020	1020	1020
4.31		Ground clearance, laden, below mast	m ₁	mm	90	90	90	90
4.32		Ground clearance, centre of wheelbase	m ₂	mm	90	90	90	90
4.33		Aisle width for pallets 1000x1200 wide*	A _{st}	mm	3600	3600	3635	3635
4.34		Aisle width for pallets 800x1200 long*	A _{st}	mm	3800	3800	3835	3835
4.35	Turning radius	W _a	mm	1980	1980	2000	2000	
4.36	Internal turning radius	b ₁₃	mm	580	580	580	580	
Performance	5.1	Travel speed, laden/unladen		km/h	14.5/16.5	14.5/16.5	14/16	14/16
	5.2	Lift speed, laden/unladen		m/s	0.36/0.60	0.36/0.60	0.34/0.60	0.34/0.60
	5.3	Lowering speed, laden/unladen		m/s	0.50/0.50	0.50/0.50	0.50/0.50	0.50/0.50
	5.5	Drawbar pull, laden/unladen ²⁾		N	4710/4900	4710/4900	4510/4810	4510/4810
	5.6	Max. drawbar pull, laden/unladen ²⁾		N	10200/8430	10200/8430	10000/8920	10000/8920
	5.7	Gradeability, laden/unladen ²⁾		%	15/22	15/22	12/20	12/20
	5.8	Max. gradeability, laden/unladen ²⁾		%	19/22	19/22	16/20	16/20
	5.9	Acceleration time, laden/unladen		s			4.8/4.1	4.8/4.1
	5.10	Service brake			hydraulic	hydraulic	hydraulic	hydraulic
	Motor	6.1	Drive motor rating S2 60min		kW	10.7	10.7	10.7
6.2		Lift motor rating S3 15%		kW	12.2	12.2	12.2	12.2
6.3		Battery acc. to DIN 43 531 35/36 A, B, C			-	-	-	-
6.4		Battery voltage/nominal capacity		V/Ah	48/450	48/730	48/565	48/730
6.5		Battery weight ³⁾		kg	765	1060	860	1060
6.6		Energy consumption acc to VDI cycle		kWh/h				
Others	8.1	Type of drive control			transistor inverter	transistor inverter	transistor inverter	transistor inverter
	8.2	Operating pressure for attachments		bar	147	147	147	147
	8.3	Oil volume for attachments		l/min	45	45	45	45
	8.4	Sound level at the driver's ear according to EN 12 053		dB(A)	67	67	67	67
	8.5	Towing coupling, type DIN						

* aisle width calculation based on VDI 2198

¹⁾ With h₃ = 3000 mm and battery weight = 765/860/1060 kg (7FB20/ 7FB25/ 7FBH20.25)

²⁾ Computed values

³⁾ Min. battery weight required by Toyota = 760/ 825/1045 kg (7FB20/ 7FB25/ 7FBH20.25)

7FB(H)20, 7FB(H)25

DIMENSIONAL DRAWINGS

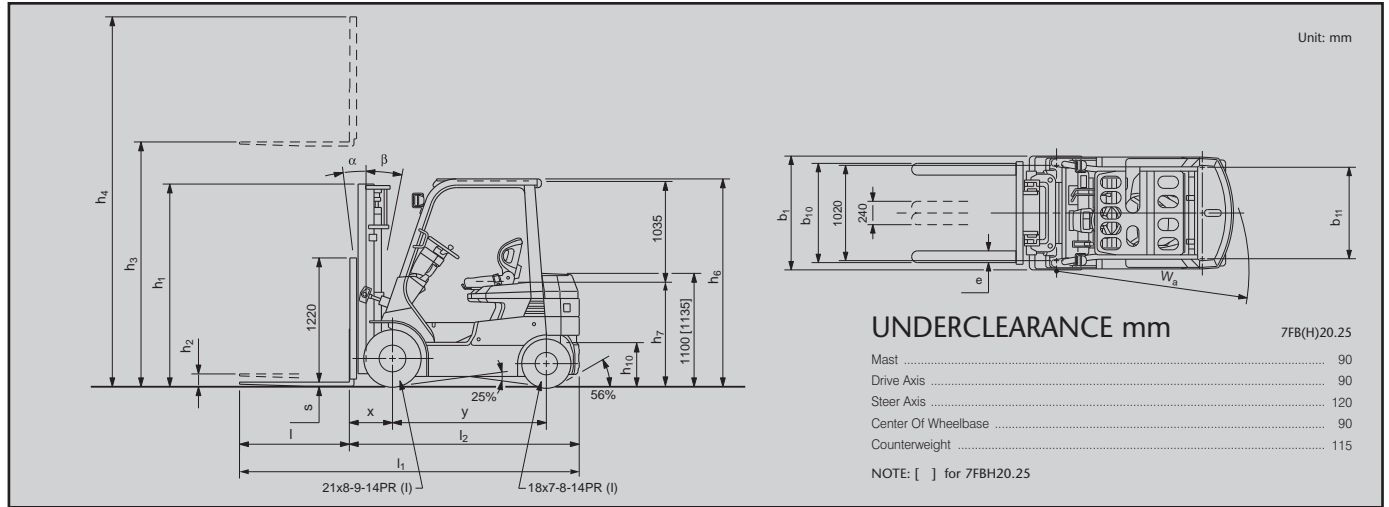

SPECIAL TREAD

Model	7FB(H)20.25		
Front Tyre Single/Dual	Single	Single	Dual
Front Tyre Size	21x8-9-14PR (l)	23x9-10-16PR (l)	6.00-9-10PR (l)
Overall Width	mm 1160	1220	1480
Tread, Front	mm 970	990	1130

MAST SPECIFICATION & RATED CAPACITIES

Model	Mast Type	Maximum Fork Height h_3	Overall Height		Free Lift			Single Tyre		Dual Tyre		
			*Lowered h_1	Extended Without Load Backrest h_4	Without Load Backrest h_2	With Standard Load Backrest h_2	Tilt Range		Load Capacity at 500 mm LC	Tilt Range		Load Capacity at 500 mm LC
							FWD	BWD		FWD	BWD	
mm	mm	mm	mm	mm	mm	deg	deg	kg	deg	deg	kg	
7FB(H)20	V	3000	1975	3670	125	125	7	11	2000	7	11	2000
		3300	2125	3970	125	125	7	11	2000	7	11	2000
		3500	2225	4170	125	125	7	11	2000	7	11	2000
		3700	2385	4370	125	125	7	11	2000	7	11	2000
		4000	2575	4670	125	125	7	11	2000	7	11	2000
		4500	2825	5170	125	125	7	5	1900	7	5	1900
	SV	3000	1975	3695	375	375	7	11	2000	7	11	2000
		3300	2125	3995	375	375	7	11	2000	7	11	2000
		3500	2225	4195	375	375	7	11	2000	7	11	2000
		3700	2385	4395	375	375	7	11	2000	7	11	2000
		4000	2575	4695	375	375	7	11	2000	7	11	2000
		4500	2825	5195	375	375	7	5	1900	7	5	1900
	FV	3000	1975	3605	1370*	755*	7	11	2000	7	11	2000
		3300	2125	3905	1520*	905*	7	11	2000	7	11	2000
		3500	2225	4105	1620*	1005*	7	11	2000	7	11	2000
		3700	2385	4305	1780*	1165*	7	11	2000	7	11	2000
		4000	2575	4605	1970*	1355*	7	11	2000	7	11	2000
		5000	3075	5695	375	375	7	5	1650	7	5	1800
	FSV	3700	1775	4345	1130*	555*	7	5	1900	7	5	1900
		4000	1875	4645	1230*	655*	7	5	1900	7	5	1900
		4300	1975	4945	1330*	755*	7	5	1850	7	5	1850
		4500	2045	5145	1400*	825*	7	5	1800	7	5	1800
		4700	2125	5345	1480*	905*	7	5	1800	7	5	1800
		5000	2225	5645	1580*	1005*	7	5	1550	7	5	1750
7FB(H)25	V	3000	1975	3665	130	130	7	11	2500	7	11	2500
		3300	2125	3965	130	130	7	11	2500	7	11	2500
		3500	2225	4165	130	130	7	11	2500	7	11	2500
		3700	2385	4365	130	130	7	11	2500	7	11	2500
		4000	2575	4665	130	130	7	5	2500	7	5	2500
		4500	2825	5165	130	130	7	5	2300	7	5	2450
	SV	3000	1975	3690	380	380	7	11	2500	7	11	2500
		3300	2125	3990	380	380	7	11	2500	7	11	2500
		3500	2225	4190	380	380	7	11	2500	7	11	2500
		3700	2385	4390	380	380	7	11	2500	7	11	2500
		4000	2575	4690	380	380	7	5	2500	7	5	2500
		4500	2825	5190	380	380	7	5	2300	7	5	2450
	FV	3000	1975	3600	1375*	755*	7	11	2500	7	11	2500
		3300	2125	3900	1525*	905*	7	11	2500	7	11	2500
		3500	2225	4100	1625*	1005*	7	11	2500	7	11	2500
		3700	2385	4300	1785*	1165*	7	11	2500	7	11	2500
		4000	2575	4600	1975*	1355*	7	11	2500	7	11	2500
		5000	3075	5690	380	380	7	5	1800	7	5	2350
	FSV	3700	1775	4340	1135*	555*	7	5	2400	7	5	2400
		4000	1875	4640	1235*	655*	7	5	2400	7	5	2400
		4300	1975	4940	1335*	755*	7	5	2300	7	5	2400
		4500	2045	5140	1405*	825*	7	5	2050	7	5	2300
		4700	2125	5340	1485*	905*	7	5	2050	7	5	2300
		5000	2225	5640	1585*	1005*	7	5	1650	7	5	2200

Note: Height of standard load backrest is 1220mm; h_4 with standard load backrest is + 550/ 555 mm (V), + 525/ 530 mm (SV), + 615/ 620 mm (FV), + 575/ 580 mm (FSV)
* with optional tyre size; 23x9-10-16PR(l), plus 20mm.
Lower fork heights available

3,000 - 3,500 kg

MAIN VEHICLE SPECIFICATIONS

Characteristics	1.1	Manufacturer			TOYOTA	TOYOTA
	1.2	Model			7FB30	7FBJ35
	1.3	Power			electric	electric
	1.4	Operator Type			rider seated	rider seated
	1.5	Load capacity/rated load	Q	kg	3000	3500
	1.6	Load centre	c	mm	500	500
	1.8	Load distance, centre of drive axle to fork	x	mm	485	500
	1.9	Wheelbase	y	mm	1650	1650
	Weight	2.1	Truck weight ¹⁾		kg	4740
2.2		Axle loadings, laden front/rear		kg	6930/810	7860/940
2.3		Axle loadings, unladen front/rear		kg	2140/2600	2230/3070
Tyres, chassis	3.1	Tyres - pneumatic (P), pneumatic shaped cushion (SE), solid rubber (R)			P	P
	3.2	Tyre size - front			28x9-15-14PR(I)	28x9-15-14PR(I)
	3.3	Tyre size - rear			6.50-10-10PR(I)	6.50-10-14PR(I)
	3.5	Wheels - number front/rear (x = driven wheels)			2x/2	2x/2
	3.6	Tread - front	b ₁₀	mm	1010	1010
	3.7	Tread - rear	b ₁₁	mm	965	965
	Dimensions	4.1	Tilt of mast/fork carriage forward/backward	α/β	deg	6/11
4.2		Height, mast lowered	h ₁	mm	2020	2110
4.3		Free lift	h ₂	mm	135	140
4.4		Lift	h ₃	mm	3000	3000
4.5		Height, mast extended	h ₄	mm	4220	4220
4.7		Height of overhead guard	h ₆	mm	2195	2195
4.8		Seat height	h ₇	mm	1150	1150
4.12		Coupling height	h ₁₀	mm	340	340
4.19		Overall length	l ₁	mm	3560	3645
4.20		Length to face of forks	l ₂	mm	2490	2575
4.21		Overall width	b ₁	mm	1240	1240
4.22		Fork dimensions	s/e/l	mm	45/120/1070	50/140/1070
4.23		Fork carriage DIN 15 173, class/type A, B			III	III
4.24		Fork carriage width	b ₃	mm	1070	1070
4.31		Ground clearance, laden, below mast	m ₁	mm	135	135
4.32		Ground clearance, centre of wheelbase	m ₂	mm	140	140
4.33		Aisle width for pallets 1000x1200 wide*	A _{st}	mm	3895	3970
4.34	Aisle width for pallets 800x1200 long*	A _{st}	mm	4095	4190	
4.35	Turning radius	W _a	mm	2210	2270	
4.36	Internal turning radius	b ₁₃	mm	620	620	
Performance	5.1	Travel speed, laden/unladen		km/h	14/15	13/15
	5.2	Lift speed, laden/unladen		m/s	0.32/0.55	0.27/0.46
	5.3	Lowering speed, laden/unladen		m/s	0.50/0.50	0.50/0.45
	5.5	Drawbar pull, laden/unladen ²⁾		N	5300/5590	5100/5490
	5.6	Max. drawbar pull, laden/unladen ²⁾		N	12160/11470	12060/12160
	5.7	Gradeability, laden/unladen ²⁾		%	11/19	9/17
	5.8	Max. gradeability, laden/unladen ²⁾		%	16/22	14/20
	5.9	Acceleration time, laden/unladen		s	4.9/4.2	
	5.10	Service brake			hydraulic	hydraulic
	Motor	6.1	Drive motor rating S2 60min		kW	11.9
6.2		Lift motor rating S3 15%		kW	14.4	14.4
6.3		Battery acc. to DIN 43 531 35/ 36 A, B, C			-	-
6.4		Battery voltage/nominal capacity		V/Ah	80/370	80/370
6.5		Battery weight ³⁾		kg	940	940
6.6		Energy consumption acc to VDI cycle		kWh/h		
Others	8.1	Type of drive control			transistor inverter	transistor inverter
	8.2	Operating pressure for attachments		bar	147	147
	8.3	Oil volume for attachments		l/min	40	40
	8.4	Sound level at the driver's ear according to EN 12 053		dB(A)	69	69
	8.5	Towing coupling, type DIN				

* aisle width calculation based on VDI 2198

¹⁾ With h₃ = 3000 mm and battery weight = 940kg (7FB30, 7FBJ35)

²⁾ Computed values

³⁾ Min. battery weight required by Toyota = 920 kg (7FB30, 7FBJ35)

DIMENSIONAL DRAWINGS

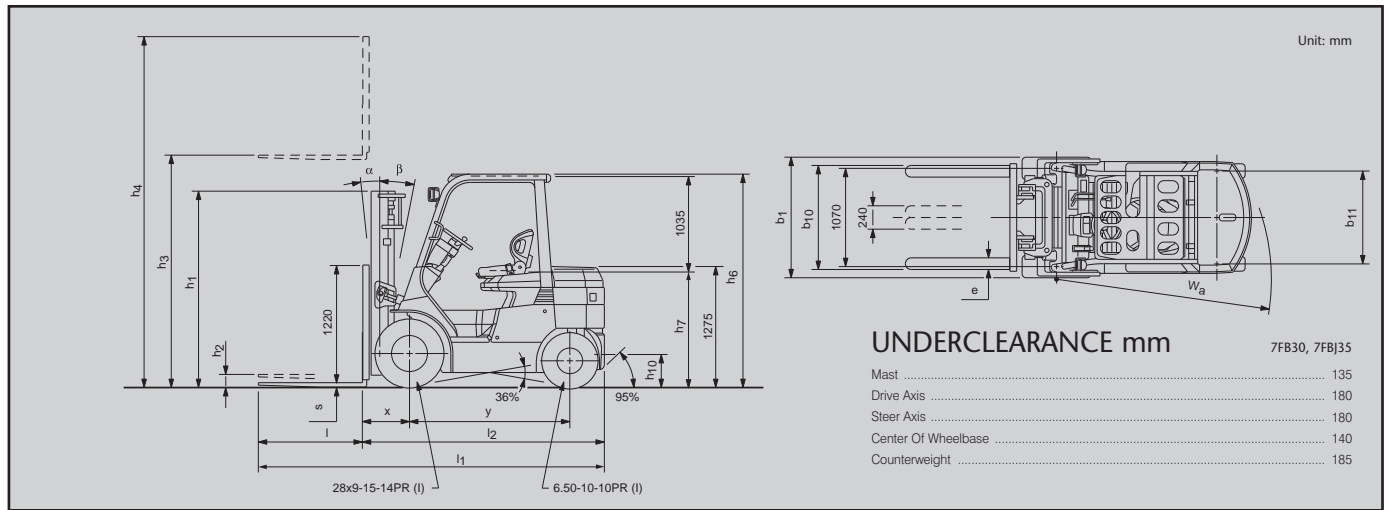

SPECIAL TREAD

Model	7FB30			7FBJ35			
Front Tyre Single/Dual	Single	Dual	Dual	Single	Dual	Dual	
Front Tyre Size	28x9-15-14PR(I)	6.00-15-10PR(I)	28x8-15-12PR(I)	28x9-15-14PR(I)	6.00-15-10PR (I)	28x8-15-12PR (I)	
Overall Width	mm	1240	1475	1675	1240	1525	1725
Tread, Front	mm	1010	1105	1240	1010	1155	1290

MAST SPECIFICATION & RATED CAPACITIES

Model	Mast Type	Maximum Fork Height	Overall Height		Free Lift			Single Tyre		Dual Tyre		
			Lowered	Extended Without Load Backrest	Without Load Backrest	With Standard Load Backrest	Tilt Range		Load Capacity at 500 mm	Tilt Range		Load Capacity at 500 mm
							FWD	BWD		FWD	BWD	
		h_3	h_1	h_4	h_2	h_2	deg	deg	kg	deg	deg	kg
		mm	mm	mm	mm	mm						
7FB30	V	3000	2020	3720	135	135	6	11	3000	6	11	3000
		3300	2170	4020	135	135	6	11	3000	6	11	3000
		3500	2270	4220	135	135	6	11	3000	6	11	3000
		3700	2430	4420	135	135	6	11	3000	6	11	3000
		4000	2620	4720	135	135	6	11	3000	6	11	3000
		4500	2870	5220	135	135	6	5	2850	6	5	3000
		5000	3120	5720	135	135	6	5	2350	6	5	3000
		3000	2020	3750	365	365	6	11	3000	6	11	3000
	SV	3300	2170	4050	365	365	6	11	3000	6	11	3000
		3500	2270	4250	365	365	6	11	3000	6	11	3000
		3700	2430	4450	365	365	6	11	3000	6	11	3000
		4000	2620	4750	365	365	6	11	3000	6	11	3000
		4500	2870	5250	365	365	6	5	2850	6	5	3000
		5000	3120	5750	365	365	6	5	2350	6	5	3000
	FV	3000	2020	3615	1405	800	6	11	3000	6	11	3000
		3300	2170	3915	1555	950	6	11	3000	6	11	3000
		3500	2270	4115	1655	1050	6	11	3000	6	11	3000
		3700	2430	4315	1815	1210	6	11	3000	6	11	3000
		4000	2620	4615	2005	1400	6	11	3000	6	11	3000
		3700	1920	4315	1305	700	6	5	3000	6	5	3000
	FSV	4000	2020	4615	1405	800	6	5	3000	6	5	3000
		4300	2170	4915	1555	950	6	5	3000	6	5	3000
		4500	2220	5115	1605	1000	6	5	2800	6	5	3000
		4700	2270	5315	1655	1050	6	5	2800	6	5	3000
5000		2430	5615	1815	1210	6	5	2400	6	5	2900	
5500		2620	6115	2005	1400	6	5	1900	6	5	2850	
6000		2870	6615	2255	1650	6	5	1450	6	5	2050	
7FBJ35		V	3000	2110	3860	140	140	6	11	3500	6	11
	3300		2290	4160	140	140	6	11	3500	6	11	3500
	3500		2390	4360	140	140	6	11	3500	6	11	3500
	3700		2490	4560	140	140	6	11	3500	6	11	3500
	4000		2740	4860	140	140	6	11	3500	6	11	3500
	4500		2990	5360	140	140	6	5	3350	6	5	3500
	5000	3240	5860	140	140	6	5	2750	6	5	3400	
	FV	3000	2110	3725	1385	890	6	11	3500	6	11	3500
		3300	2290	4025	1565	1070	6	11	3500	6	11	3500
		3500	2390	4225	1665	1170	6	11	3500	6	11	3500
		3700	2490	4425	1765	1270	6	11	3500	6	11	3500
		4000	2740	4725	2015	1520	6	11	3500	6	11	3500
		3700	2020	4425	1295	800	6	5	3500	6	5	3500
	FSV	4000	2170	4725	1445	950	6	5	3500	6	5	3500
		4300	2225	5025	1495	1005	6	5	3500	6	5	3500
		4500	2270	5225	1545	1050	6	5	2900	6	5	3400
		4700	2430	5425	1705	1210	6	5	2900	6	5	3400
		5000	2620	5725	1895	1400	6	5	2500	6	5	3300
		5500	2870	6225	2145	1650	6	5	1950	6	5	2900
		6000	3120	6725	2395	1900	6	5	1500	6	5	2200

Note: Height of standard load backrest is 1220mm; h_4 with standard load backrest is + 500/360 mm (7FB30/35 V), + 470 mm (7FB30 SV), + 605/ 495 mm (7FB30/35 FV), + 605/495 mm (7FB30/35 FSV)
Lower fork heights available

7FB15.18.20.25.30, 7FBJ35

- Toyota SAS (System of Active Stability)
- Toyota AC² power system
- Toyota OPS (Operator Presence Sensing)
- Toyota ORS (Operator Restraint System) seat
- Wide visible mast [MFH: 3000 mm]
- Load backrest [Height: 1220 mm]
- Long forks [Length: 1070 mm]
- Long forkbar [Length: 920 mm (7FB15.18); 1020 mm (7FB20.25); 1070 mm (7FB30, 7FBJ35)]
- 2-way valve
- Dual brake system
- Pneumatic tyres
- Full hydraulic power steering
- Headlights
- Digital multifunction display
- Memory tilt steering column
- Emergency lever

*When dual tyres are selected, the Active Control Rear Stabilizer function of the System of Active Stability (S.A.S.) is not included.

The data in this spec sheet was determined based on our standard testing condition. Operating performance may vary depending on the actual specification and condition of the truck as well as the condition of the operating area. Availability and specifications are determined regionally and are subject to change without notice. Please consult your Toyota representative for details.